



Differential pressure transmitter



Huba Control

Relative and differential pressure transmitter

Type 692

Type 692 pressure transmitters have a unique, well proven ceramic technology. There are variety of pressure and electrical connections available, together with several standardised output signals. The wide variety of options makes these transmitters ideal for applications across a broad spectrum of industries.

Pressure range
0 ... 0.1 – 25 bar

- + Very low temperature sensitivity
- + High resistance to extreme temperatures
- + No mechanical creepage
- + Modular system and choice of materials to suit individual applications

Technical overview

Pressure range

Relative and differential 0 ... 0.1 – 25 bar

Operating conditions

Medium		Liquids and neutral gases
Temperature	Medium / ambient	-15 ... +85 °C
	Storage	-40 ... +85 °C
Tolerable overload on one side		See order code selection table
System pressure	≤ 6 bar	PVDF 12 bar
	≥ 10 bar	Stainless steel 1.4305 / AISI 303 25 bar
Rupture pressure		50 bar
		1.5x system pressure

Materials

Case		Stainless steel 1.4305 / AISI 303
Materials in contact with the medium	Pressure connection	Stainless steel 1.4305 / AISI 303, PVDF, CuZn nickel plated
	Sensor	ceramic Al ₂ O ₃ (96%)
	Sealing material	FPM, EPDM, NBR, MVQ

Electrical overview

2 wire	Output 4 ... 20 mA	Power supply 11 ... 33 VDC	Load $< \frac{\text{supply voltage} - 11V}{0.02 A}$ [Ohm]	Current consumption (at nominal pressure) < 20 mA
	0 ... 5 V	11 ... 33 VDC / 24 VAC ±15%	>10 kOhm	< 5 mA
3 wire	0 ... 10 V	18 ... 33 VDC / 24 VAC ±15%	>10 kOhm	< 5 mA
	ratiom. 10 ... 90%	5 VDC ±5%	>10 kOhm	< 5 mA
Polarity reversal protection	Short circuit proof and protected against polarity reversal. Each connection is protected against crossover up to max. supply voltage.			

Dynamic response

Response time	< 5 ms
Load cycle	< 50 Hz

Electrical connection

Connector DIN EN 175301-803-A
Connector DIN EN 60130-9
Cable 1.5 m (PG7)

Protection standard

IP 65
IP 65
IP 65

Pressure connection

Pressure tube tip	Ø 4 mm Ø 6 mm
Pipe fitting	Ø 6 mm Ø 8 mm
Outside thread	1/16"-20 UNF G 1/8"
Inside thread	1/8"-27 NPT G 1/8"

Mounting instruction

Installation arrangement	Unrestricted
Mounting	Mounting bracket

Tests / Admissions

Electromagnetic compatibility CE conformity acc. EN 61326-2-3

Weight

~ 430 g

Packaging

Single packaging in cardboard accessories included

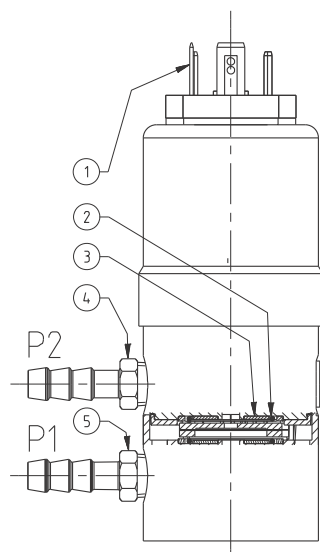

Legend to cross-section drawing

- 1 Electrical connection
- 2 Seals
- 3 Ceramic element
- 4 P2 Pressure connection (lower pressure)
- 5 P1 Pressure connection (higher pressure)

Accuracy

Parameter	Unit	Versions with overload on one side < 2x nominal pressure	Versions with overload on one side < 3x nominal pressure	Versions with overload on one side < 7.5x nominal pressure
Tolerance zero point	max. % fs	±0.4	±0.75	±1.25
Tolerance full scale	max. % fs	±0.4	±0.75	±1.25
Resolution	% fs	0.1	0.15	0.25
Total of linearity, hysteresis and repeatability	max. % fs	±0.5	±0.75	±1.25
Long term stability acc. to DIN EN 60770	% fs	±0.5	±0.5	±0.5
TC zero point ¹⁾	max. % fs/10K	See order code selection table	See order code selection table	See order code selection table
TC sensitivity ¹⁾	max. % fs/10K	±0.15	±0.23	±0.38

Test conditions: 25 °C, 45% RH, Power supply 24 VDC
TC z.p. / TC s. -15 ... +80 °C

Order code selection table	1	2	3	4	5	6	7	8	9	10
692.	X	X	X	X	X	X	X	X	X	X

Pressure range ²⁾	Tolerable overload on one side		TC z.p. (fs/10K)		1	2	3	4	5	6	7	8	9	10	
	P1	P2													
0 ... 0.1 bar	max. 0.6 bar	0.6 bar	(6 x Nominal pressure)	± 1.2 %	9	0	0								
0 ... 0.2 bar	max. 1.2 bar	1.2 bar	(6 x Nominal pressure)	± 1.2 %	9	0	2								
0 ... 0.2 bar	max. 0.6 bar	0.6 bar	(3 x Nominal pressure)	± 0.6 %	9	4	0								
0 ... 0.25 bar	max. 1.2 bar	1.2 bar	(4.8 x Nominal pressure)	± 1.0 %	9	0	3								
0 ... 0.25 bar	max. 0.6 bar	0.6 bar	(2.4 x Nominal pressure)	± 0.5 %	9	4	1								
0 ... 0.3 bar	max. 0.6 bar	0.6 bar	(2 x Nominal pressure)	± 0.4 %	9	0	1								
0 ... 0.4 bar	max. 1.2 bar	1.2 bar	(3 x Nominal pressure)	± 0.6 %	9	0	4								
0 ... 0.4 bar	max. 2 bar	2 bar	(5 x Nominal pressure)	± 1.0 %	9	0	5								
0 ... 0.5 bar	max. 1.2 bar	1.2 bar	(2.4 x Nominal pressure)	± 0.5 %	9	0	6								
0 ... 0.5 bar	max. 3 bar	3 bar	(6 x Nominal pressure)	± 0.8 %	9	0	7								
0 ... 0.6 bar	max. 1.2 bar	1.2 bar	(2 x Nominal pressure)	± 0.4 %	9	0	8								
0 ... 0.6 bar	max. 3 bar	3 bar	(5 x Nominal pressure)	± 0.7 %	9	0	9								
0 ... 1 bar	max. 2 bar	2 bar	(2 x Nominal pressure)	± 0.4 %	9	1	1								
0 ... 1 bar	max. 5 bar	5 bar	(5 x Nominal pressure)	± 1.0 %	9	1	2								
0 ... 1.6 bar	max. 3.2 bar	3.2 bar	(2 x Nominal pressure)	± 0.4 %	9	1	3								
0 ... 1.6 bar	max. 12 bar	12 bar	(7.5 x Nominal pressure)	± 1.0 %	9	1	4								
0 ... 2.5 bar	max. 5 bar	5 bar	(2 x Nominal pressure)	± 0.4 %	9	1	5								
0 ... 2.5 bar	max. 12 bar	12 bar	(4.8 x Nominal pressure)	± 0.6 %	9	1	6								
0 ... 4 bar	max. 8 bar	8 bar	(2 x Nominal pressure)	± 0.4 %	9	1	7								
0 ... 4 bar	max. 12 bar	12 bar	(3 x Nominal pressure)	± 0.5 %	9	1	8								
0 ... 6 bar	max. 12 bar	12 bar	(2 x Nominal pressure)	± 0.4 %	9	1	9								
0 ... 10 bar	max. 20 bar	20 bar	(2 x Nominal pressure)	± 0.4 %	9	3	0							1,4	
0 ... 16 bar	max. 32 bar	32 bar	(2 x Nominal pressure)	± 0.4 %	9	3	1							1,4	
0 ... 25 bar	max. 50 bar	50 bar	(2 x Nominal pressure)	± 0.4 %	9	3	2							1,4	
▲ Fullscale signal at these pressures															
Sealing material	FPM	Fluoro elastomer							0						
	EPDM	Ethylene propylene							1						
	NBR	Butadiene Acrylonitrile							2						
	MVQ	Silicone polymer							3						
Adjustment	Factory								0						
	0 ... 5 V	11 ... 33 VDC / 24 VAC ±15%							0						
Output / power supply	0 ... 10 V	18 ... 33 VDC / 24 VAC ±15%							1						
	4 ... 20 mA	11 ... 33 VDC							7						
	ratiom. 10 ... 90%	5 VDC ±5%							9						
Electrical connection	Cable 1.5 m, PG7												0		
	Connector ³⁾	DIN EN 175301-803-A DIN EN 60130-9											1		
Pressure connection	Inside thread	Stainless steel 1/8 -27 NPT or PVDF G 1/8												0	
	Hose connection	CuZn nickel plated	for tube inside Ø 4 mm												1,4
		Stainless steel 1.4571 / AISI 316Ti	for tube inside Ø 4 mm												E 1,4
		CuZn nickel plated	for tube inside Ø 6 mm												2 1,4
		PVDF	for tube inside Ø 6 mm												3 2
	Pipe fitting	Stainless steel 1.4571 / AISI 316Ti	for pipe outside Ø 6 mm												D 1,4
		CuZn nickel plated	for pipe outside Ø 6 mm												4 1,4
		Stainless steel 1.4305 / AISI 303	for pipe outside Ø 6 mm												5 1,4
		PVDF	for pipe outside Ø 6 mm												8 2
		CuZn nickel plated	for pipe outside Ø 8 mm												6 1,4
		Stainless steel 1.4305 / AISI 303	for pipe outside Ø 8 mm												7 1,4
	Outside thread	7/16 -20 UNF CuZn nickel plated													9 2
Adapter inside	G 1/8 Stainless steel 1.4305 / AISI 303													A 1,4	
Adapter outside	G 1/8 CuZn nickel plated with union nut													B 1,4	
Case	Stainless steel 1.4305 / AISI 303														C 1,4
	PVDF to 6 bar max.														1
	Stainless steel with pressure tip orifice														2
Pressure range variation (optional)															4
	Indicate W and state range on order (e.g.: W0... + 8bar/OUT1...6V)														W

Accessories (supplied loose)

Order number

Female connector DIN EN 175301-803-A with seal	IP 65, when installed and screwed	103510
Female connector DIN EN 60130-9	IP 65, when installed and screwed	103524
Mounting bracket incl. screws		101999
Calibration certificate		104551

¹⁾ TC = Temperature coefficient

²⁾ Other pressure range on request

³⁾ Delivery without female connector

Female Connector
DIN EN 60130-9

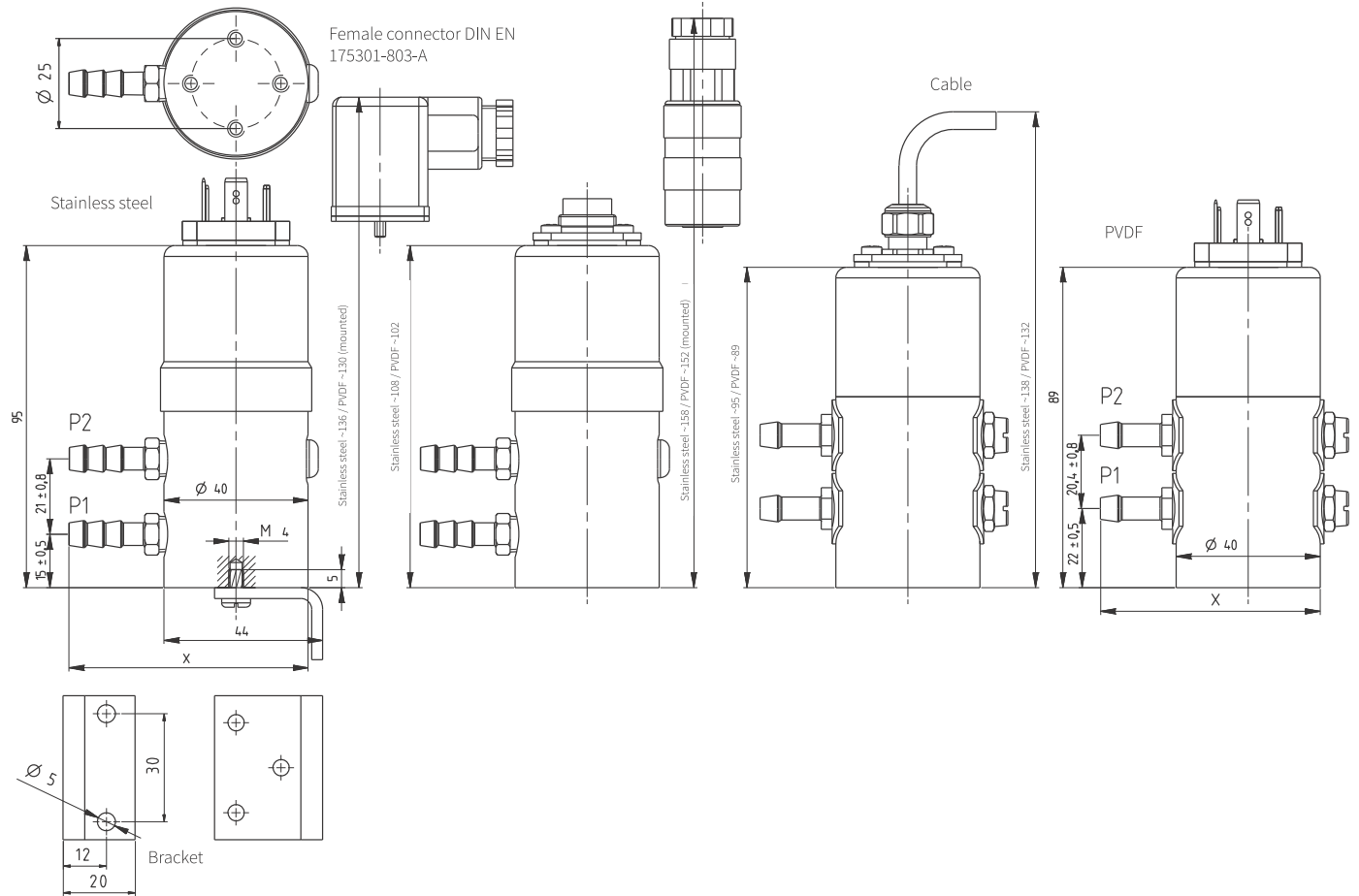

	Stainless steel 1.4305	Screw fitting for pipe outside Ø 6	L~24	a=10
	AISI 303	Screw fitting for pipe outside Ø 8	X~65	b=12
	Stainless Steel 1.4305	Inside thread G 1/8	L~12	a=14
	AISI 303		X~53	
	CuZn nickel plated	Screw fitting for pipe outside Ø 6	L~24	a=10
		Screw fitting for pipe outside Ø 8	X~65	b=12
	CuZn nickel plated	Screw fitting for pipe outside Ø 6	L~25	a=12
		Screw fitting for pipe outside Ø 8	X~66	b=14
	CuZn nickel plated	Hose connection for tube Ø 4	L~20	a=10
	Stainless steel 1.4571	Hose connection for tube Ø 6	X~61	
	AISI 316Ti	Hose connection for tube Ø 4	L~25	a=10
		Hose connection for tube Ø 6	X~66	
	CuZn nickel plated	Outside thread G 1/8	L~20	a=10
			X~61	b=12
	CuZn nickel plated	Outside thread 7/16-20 UNF	L~18	a=14
			X~59	
	PVDF	Screw fitting for pipe Ø 6	L~20	a=12
		Screw fitting for pipe Ø 8	X~61	
	PVDF	Screw fitting for pipe Ø 6	L~23	a=14
		Screw fitting for pipe Ø 8	X~64	
	PVDF	Hose connection for tube Ø 6	L~20	a=10
			X~61	

